

Rotary Shaft

TORQUE SENSOR

with Brushless Data Transmission System

TLT
Series

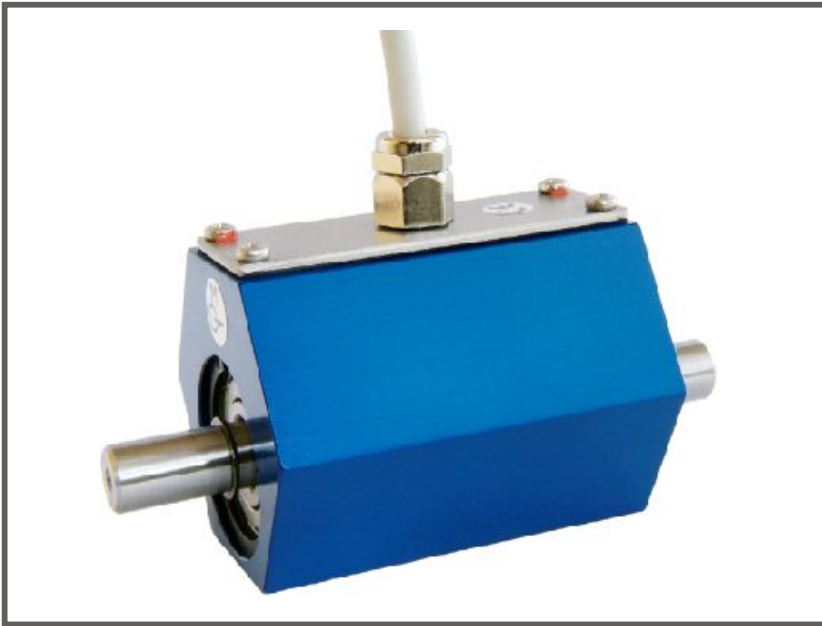

- Torque Ranges: 0-0.2Nm to 0-200Nm
- 0.25% Accuracy
- ± 5 Vdc Output
- Suitable for continuously rotating applications
- Inductive non-contact data transmission system gives operating speeds up to 8000rpm
- 3 YEAR WARRANTY

Options Available

Special couplings can be manufactured to order
 ± 10 Vdc Output

Supplied With Any Instrumentation and Calibrated as
a Complete System with Traceable Certificate

DESCRIPTION

The TLT series of torque transducers provides low-cost option for high-speed, high accuracy “in-line” torque measurement by utilising strain gauged shaft and ‘non-contact’ inductive technology.

The signal from the strain gauge bridge is converted into a modulated frequency that is proportional to the measured torque. This signal is transferred from a rotating coil to a static coil for processing by the on-board amplifier. Excitation voltage is also transferred using this system.

A ± 5 Vdc output is provided as standard with ± 10 Vdc as an option.

The TLS/TLSM series can be additionally be accompanied by any of our range of instrumentation to offer a complete system, supplied and calibrated from a single supplier.

Transducer Specialists...

APPLIED MEASUREMENTS LIMITED

3 MERCURY HOUSE - CALLEVA PARK - ALDERMASTON - BERKSHIRE - RG7 8PN - UK

Tel: (+44) 0118 981 7339 Fax: (+44) 0118 981 9121 email: info@appmeas.co.uk Internet: www.appmeas.co.uk



SPECIFICATION

CHARACTERISTICS	TLT	UNITS
Maximum Torque Ranges:	0-0.2, 0-0.5, 0-1, 0-2, 0-5, 0-10, 0-15, 0-20, 0-50, 0-100, 0-200	Nm
Rated Output (FSO):	±5 (±10 optional)	Vdc
Excitation Voltage:	12-28	Vdc
Supply Current:	<90	mA
Safe Overload:	150	% FSO
Accuracy Class:	<0.25	±% FSO
Repeatability:	<0.05	±% FSO
Operating Temperature Range:	0 to +60	°C
Zero Temperature Shift:	<0.04	±%FSO/°C
Span Temperature Shift:	<0.02	±%FSO/°C
Environmental Protection:	IP50	

Capacity (Nm)	Max Speed (rpm)	Torsional Stiffness (Nm/rad)	Mass Moment of Inertia - Drive Side (kg/m ²)	Mass Moment of Inertia - Test Side (kg/m ²)	Max Axial Thrust (N)
0,2	8000	1,8*10 ¹	1,6*10 ⁻⁶	1,0*10 ⁻⁶	20
0,5	8000	1,1*10 ²	1,6*10 ⁻⁶	1,0*10 ⁻⁶	30
1	8000	3,6*10 ²	1,6*10 ⁻⁶	1,1*10 ⁻⁶	40
2	8000	3,5*10 ²	1,6*10 ⁻⁶	1,1*10 ⁻⁶	40
5	8000	8,9*10 ²	1,7*10 ⁻⁶	1,1*10 ⁻⁶	50
10	8000	8,9*10 ²	1,7*10 ⁻⁶	1,1*10 ⁻⁶	50
15	8000	8,9*10 ²	1,7*10 ⁻⁶	1,1*10 ⁻⁶	50
20	6000	8,4*10 ³	4,2*10 ⁻⁵	2,1*10 ⁻⁵	1600
50	6000	8,4*10 ³	4,2*10 ⁻⁵	2,1*10 ⁻⁵	1600
100	6000	2,0*10 ⁴	4,7*10 ⁻⁵	2,7*10 ⁻⁵	3000
200	6000	2,0*10 ⁴	4,7*10 ⁻⁵	2,7*10 ⁻⁵	3000

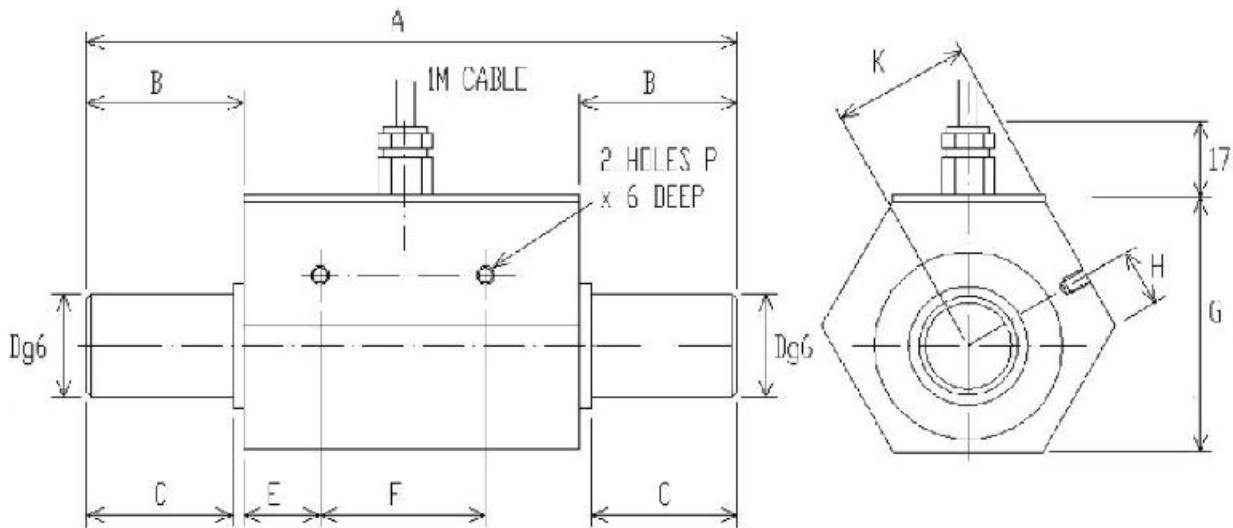

Capacity (Nm)	A	B	C	D	E	F	G	H	K	P
0-0.2 to 0-2	100	17,5	17	8	15	35	46	8	26	M4
0-5 to 0-15	100	17,5	17	10	15	35	46	8	26	M4
0-20, 0-50	140	30	29	18	20	40	65	15	34,8	M5
0-100, 0-200	160	40	39	22	20	40	65	15	34,8	M5

